

Get Smart With Your Data

Annalise Suzuki

VP, Technology & Engagement

PLM Road Map @ GPDIS

September 27, 2022

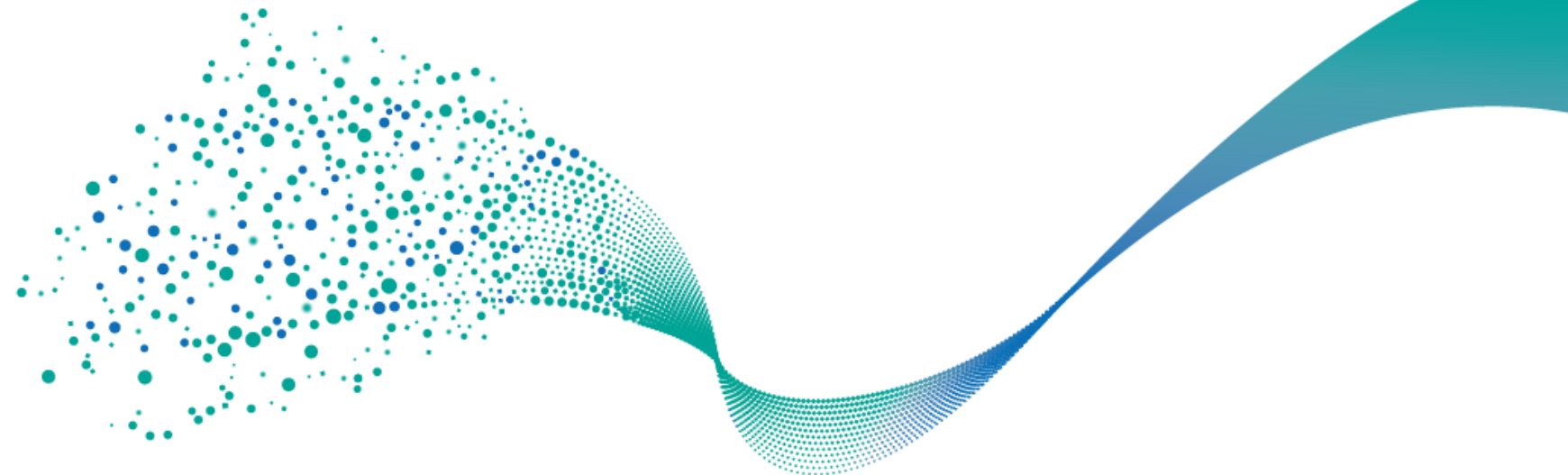

Elevating Your Data as Assets

- Leveraging Data Resilience for Sustainability

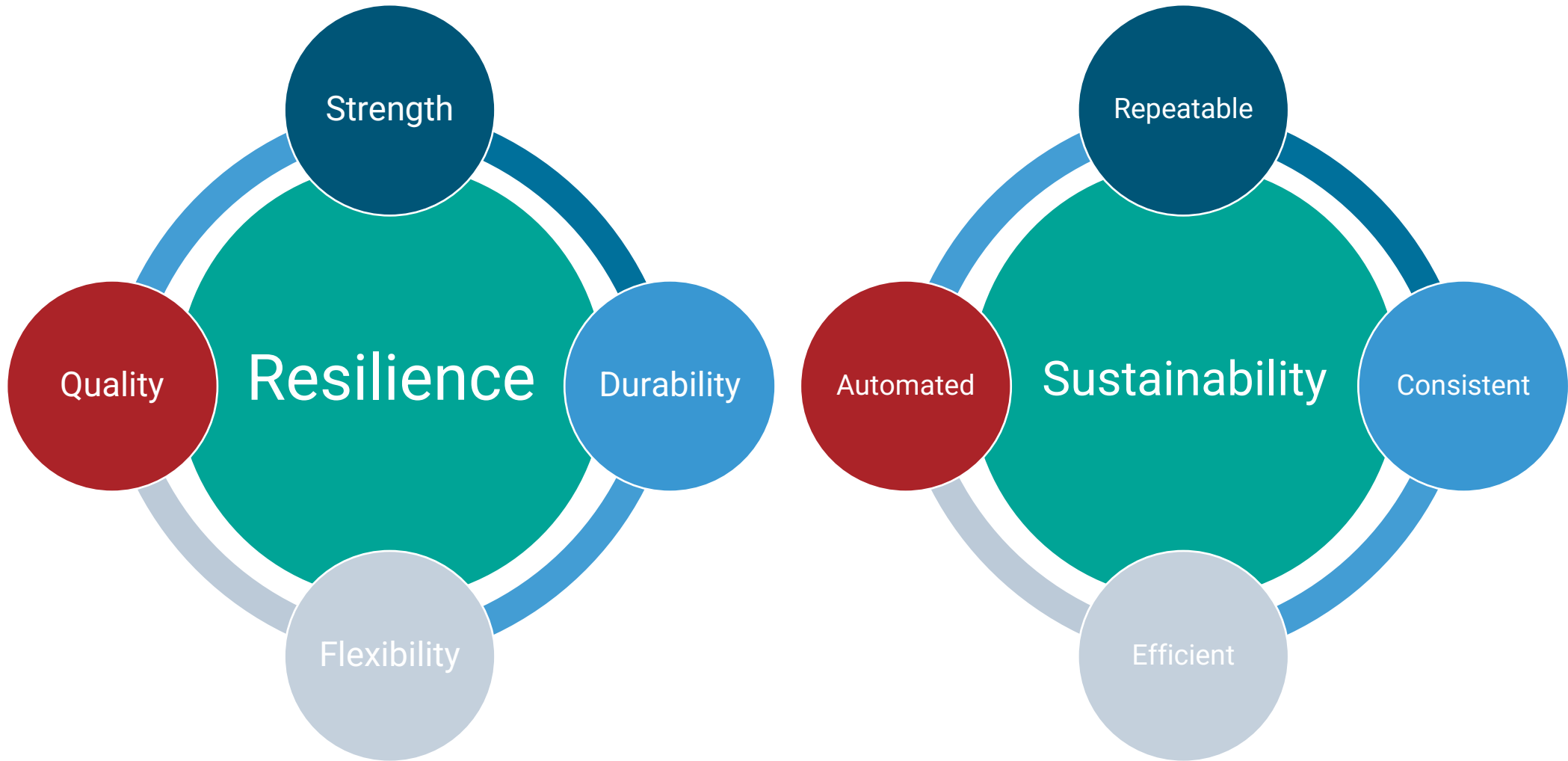

What is your data?

PLM

ERP

MES

CAD

Configurations

Materials

Cost

Price

Logistics

Capacity

Performance

Geometry

Tolerances



Data: What to Identify

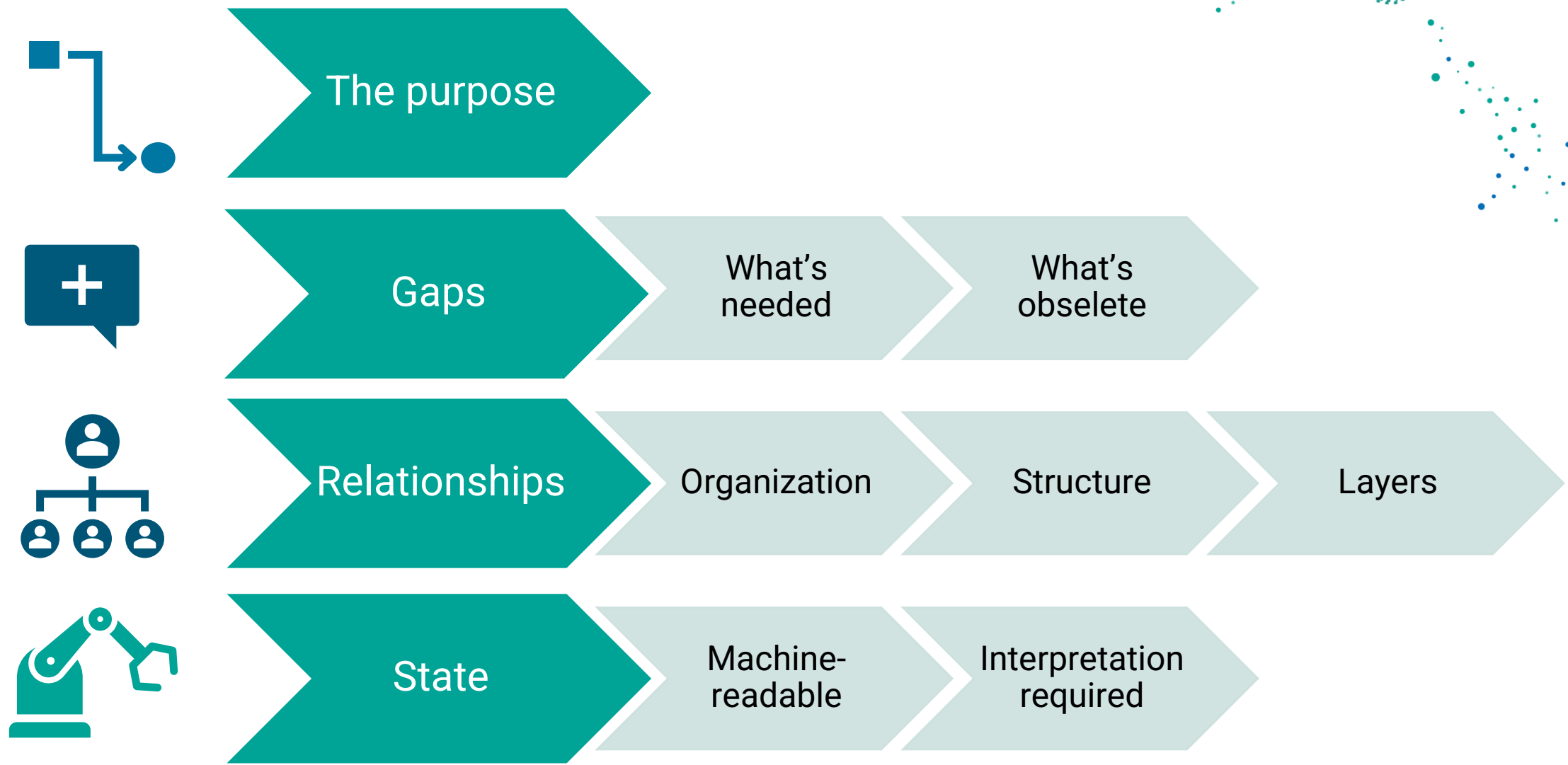

Elevating data asset: Automate face color to define manufacturing process

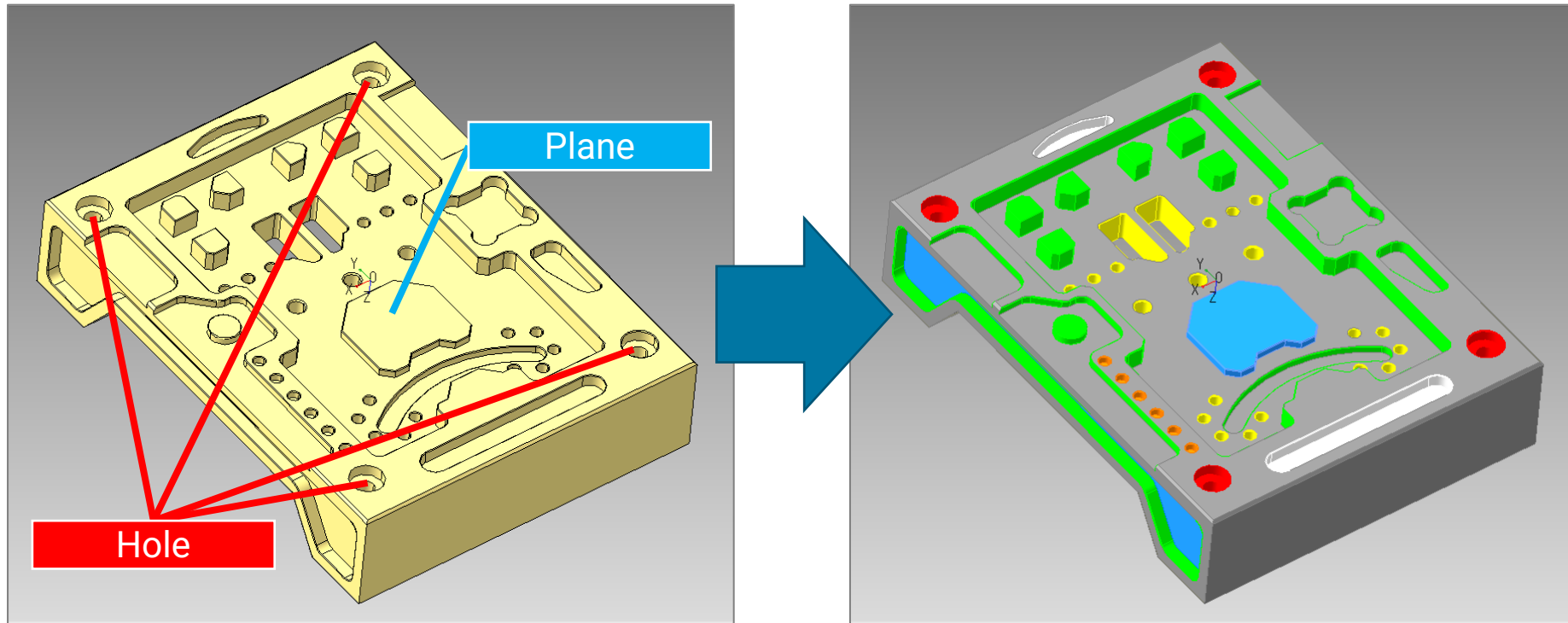

Elevating data asset: Automate removal by geometric type

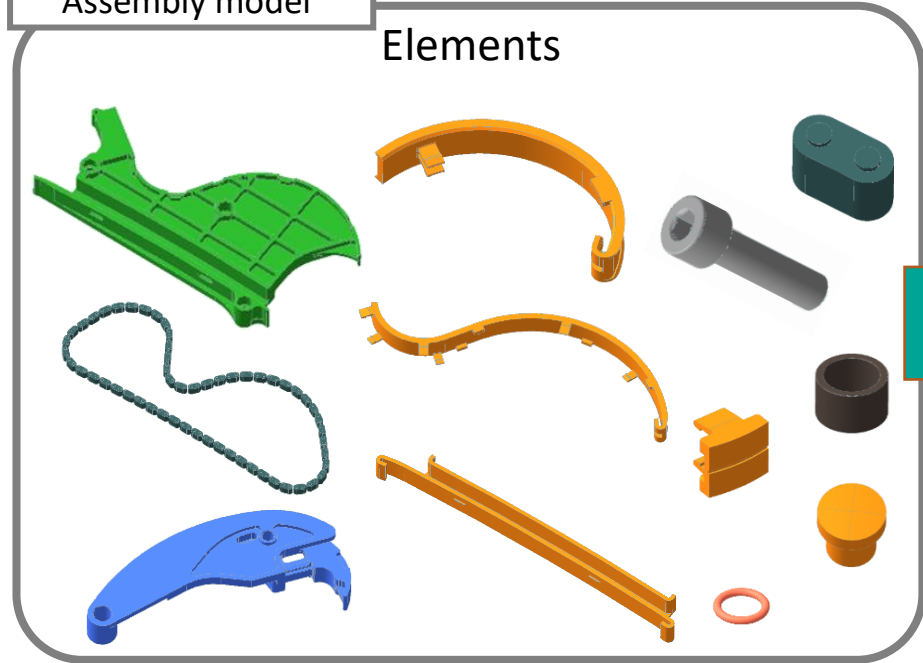
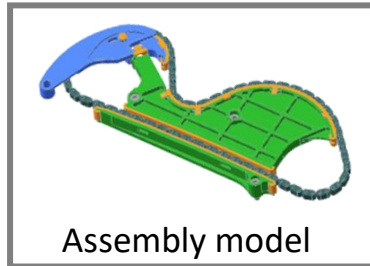

Any specified components can also be deleted for IP protection or simplification

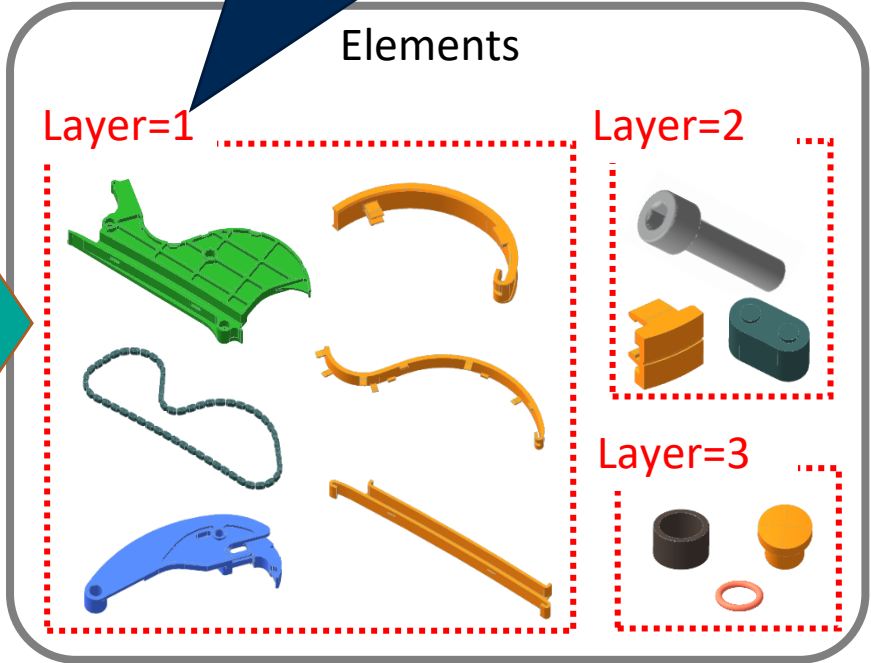

Internal vs. External

- Internal organization: data creators & consumers
- External organization(s):
 - Data consumers
 - What they need
 - For what purpose

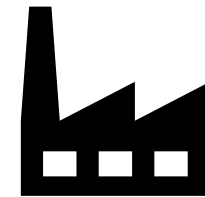
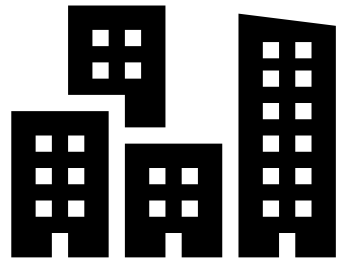

Industry Reality: Customer Story

- OEM “A” delivers Technical Data Package (*drawingless!*) to supplier
 - 3D PDF
 - PRC (visual with associative PMI)
 - STEP (geometry)
 - Attributes / BOM in 3D PDF
- Supplier “X”:
 - Creates drawing
 - Balloons drawing
 - Creates inspection process

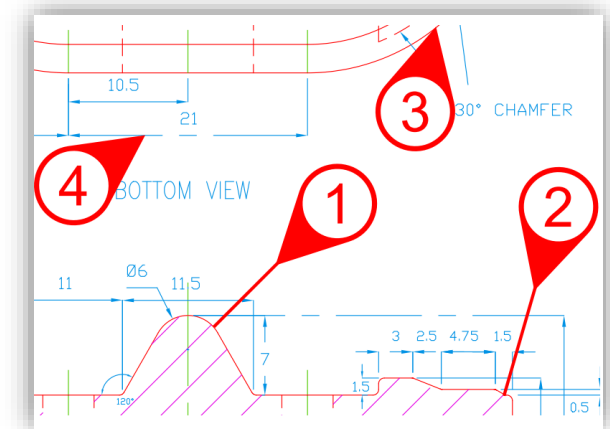
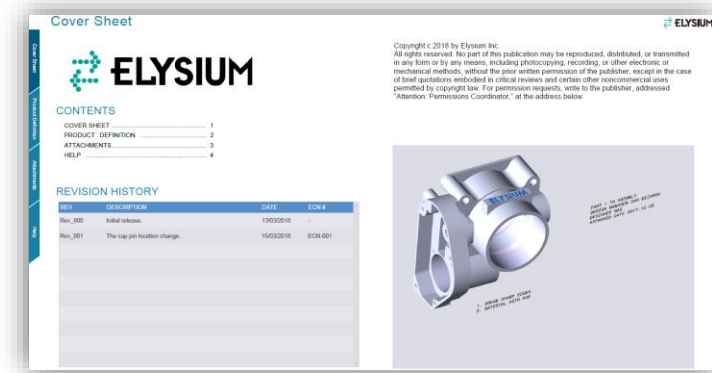

OEM "B": Elevating Data

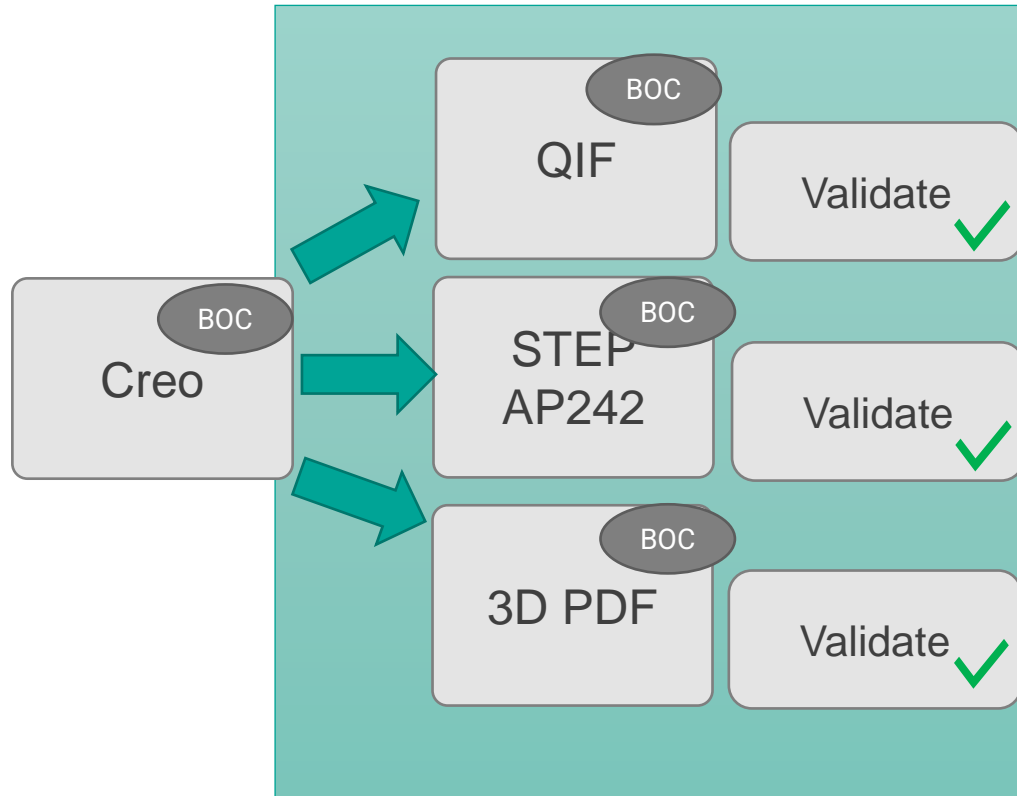

Quality Deliverables:

- Machine-readable
- Automate Inspection
- Trace feedback

OEM "C" Elevating Data Asset

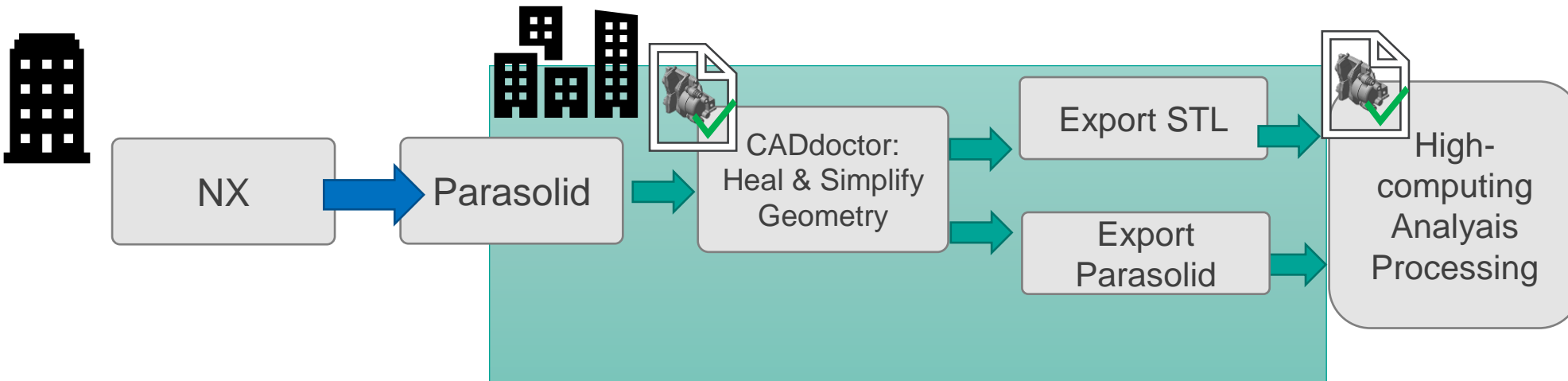
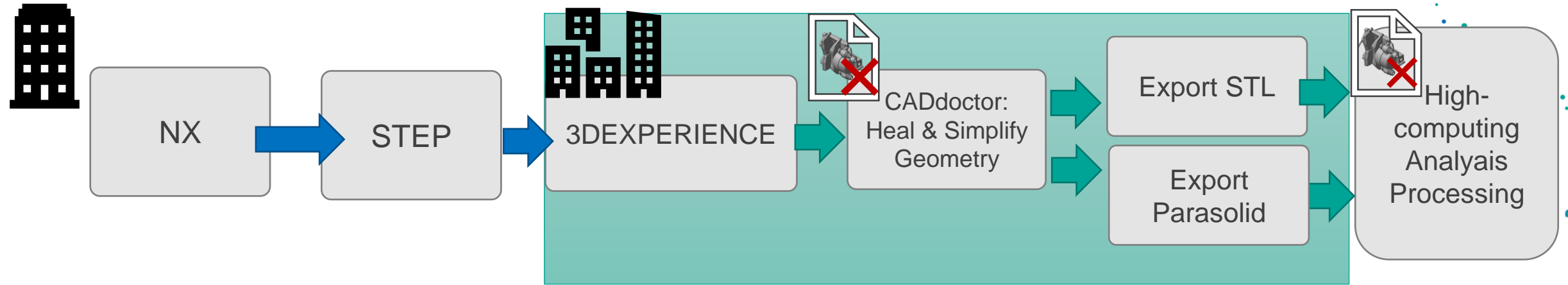

Strategize: Ask Yourself

- What can be implemented in a standardized way?
 - Resources
 - Formats / Templates
 - Processes
- What can be pushed ahead of a standard?
 - Organizational strengths
 - Differentiators
 - Low risk, high value/return

